

Rail-Demux User Guide

(Version 2)

DMX512 to analogue conversion has two key applications: Upgrading older analogue dimmers and driving fluorescent ballasts.

Rail-Demux is an elegant solution to both applications and provides 16 analogue outputs with DMX512 and RDM (Remote Device Management) Draft V1.0 support. It is housed in a high impact DIN Rail mounting case.

The control interface uses DMX512 and RDM or Remote Device Management. The RDM interface allows the start address to be set by the console over the DMX512 cable. RDM also allows the product to receive firmware upgrades and run diagnostics tests. This can be done using any of the following products: Net-Lynx OP, Ether-Lynx or Jump-Start.

Specification:

Input Voltage:	24V DC
Maximum Current:	1.5A
Output Voltage:	0-10V DC 4mA (option for 0-370uA Output)
Internal Fuse:	2A Slow Blow 20mm
Duty Cycle:	100%
Dimensions:	W:88 H:90 D:58mm
Mounting:	DIN Rail or surface mount
IP:	Indoor use only
Listings:	CE, FCC
Max Wire Size:	2.5mm ²

Power Supply Options: (order separately)

PSU-24-2-FER	
Output:	24V 2A
Input:	Auto-sensing
Power:	48W
Listing:	CE / FCC / UL / PSE

PSU-24-5-FER	
Output:	24V 5A
Input:	Auto-sensing
Power:	120W
Listing:	CE / FCC / UL / PSE

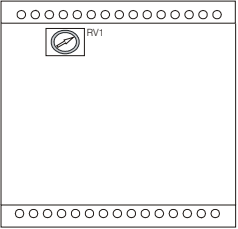

Rail-Demux Operation:

0 to 10V Output	<p>To adjust or calibrate the output of the Rail-Demux, use the following procedure:</p> <ul style="list-style-type: none"> ❑ Disconnect the power supply ❑ Gently remove the lid of the DIN rail unit ❑ Locate RV1. This is the calibration resistor. This will allow you to decrease or increase the output voltage range ❑ Replace lid and reconnect to the power supply 
0 to 370uA Output	<p>This option is only possible by returning the unit to Artistic Licence. Once modification has been made you can calibrate the unit using the procedure above.</p>
Note	<p>Ensure that you are grounded before touching any internal components. You can achieve this by either wearing an anti-static wristband or by touching an earthed metal surface at regular intervals.</p>

Rail-Demux Wiring Diagram:

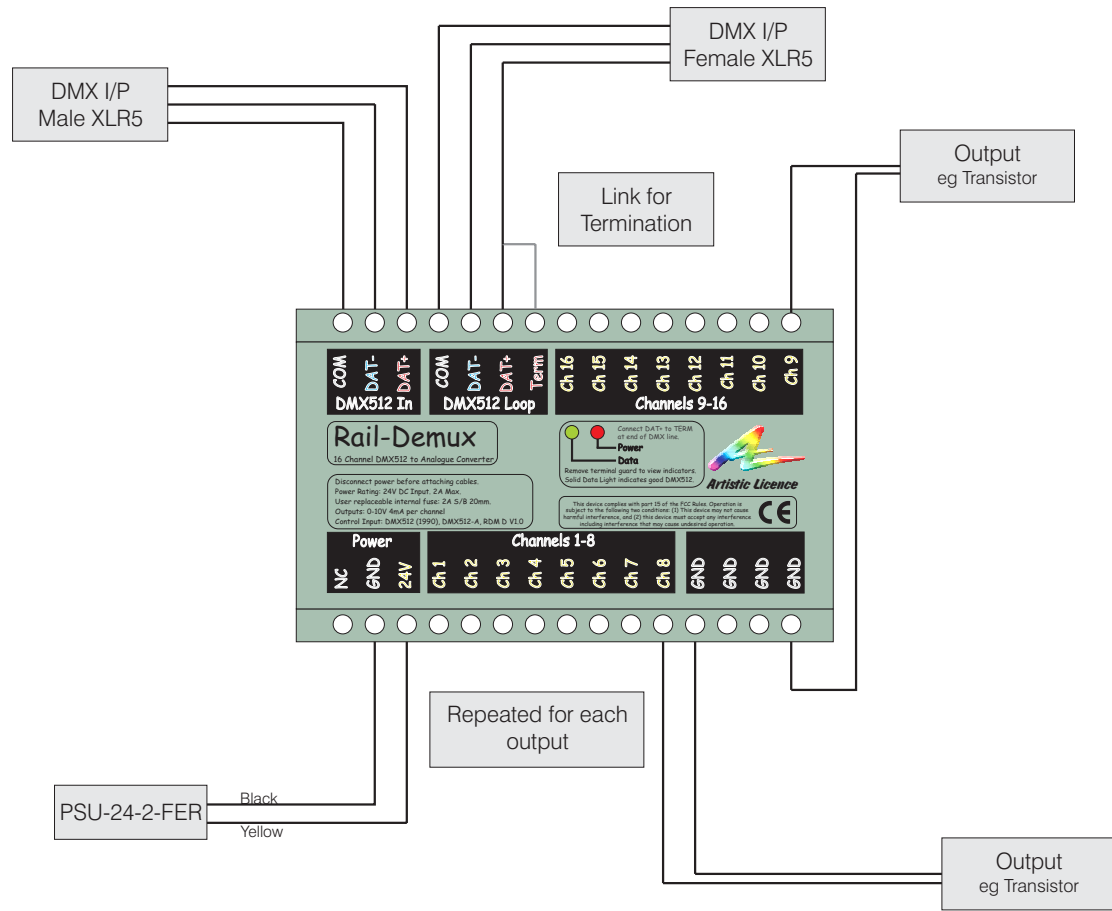

DMX512 Wiring:

XLR Pin	Function	Colour
1	Ground	Black
2	Data -	Blue
3	Data +	Red
4	No Connection	
5	No Connection	

DIN Rail Surface Mounting:

To use the surface mount option push the three bottom tabs out until they click into place. We recommend using an M4 Pan head screw.

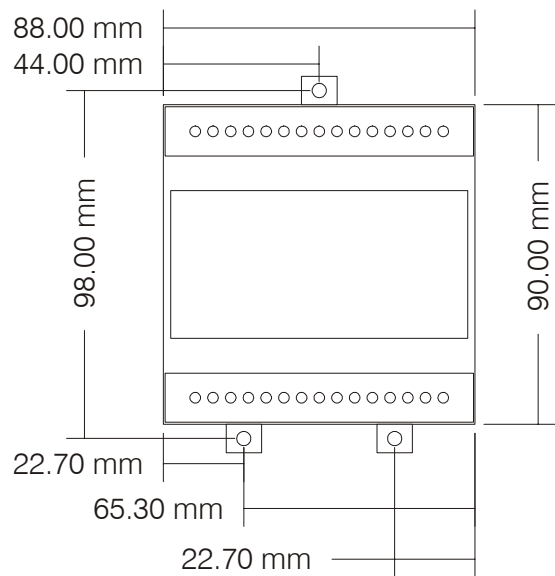

The DIN Rail Range:

- ❑ Rail-Split RDM – A fully bi-directional six channel DMX512 splitter and distribution amplifier
- ❑ Rail-Pipe – A six channel intelligent power supply / low voltage dimmer
- ❑ Rail-Switch – Provides six mains voltage relays with DMX512 and RDM Draft V1.0 support
- ❑ Rail-Demux – Provides 16 DMX512 to analogue outputs and RDM Draft V1.0 support
- ❑ Rail-Tran – Provides six Darlington transistor outputs, operation to 50V DC at 450mA, product total 750mA
- ❑ Pixi-Power SB1 – A power and data controller for Pixi-Bulb and Pixi-Strip
- ❑ Rail-DALI – A 256 channel bi-directional DMX / DALI interface

Artistic Licence

© Artistic Licence (UK) Ltd. 2004 - 2005
B1 & B3 Livingstone Court
Peel Road
Harrow
Middlesex
England
HA3 7QT
Tel: +44 (0)20 88 63 45 15
Fax: +44 (0)20 84 26 05 51
Email: Sales@ArtisticLicence.com



The information contained in this document is subject to change without notice. Artistic Licence (UK) Ltd. makes no warranty of any kind with regard to this material, including, but not limited to, the implied warranties of fitness for a particular purpose.

Artistic Licence (UK) Ltd. shall not be liable for errors contained herein or for incidental or consequential damages in connection with the furnishing, performance or use of this material. All trademarks are acknowledged.